

Gyrofocus

1968

DESIGN: DOMINIQUE IMBERT

With its singular style and hearth that rotates 360°, the Gyrofocus has earned its place as an icon of contemporary design alongside the most legendary names in furniture and interior design.

Focus's flagship model, the Gyrofocus was voted the "Most Beautiful Object in the World" in an Italian design competition and has been exhibited at the Guggenheim Museum in New York.



focus®

CREATE BEYOND CONVENTION

Gyrofocus

outdoor (wood-burning)



The outdoor models are available with a black anti-corrosion finish or a rusted finish, both developed by Focus for exterior use. The rusted surface gradually changes, so the patina gains character over time.



Gyrofocus

outdoor (wood-burning)



DIMENSIONS / WEIGHT

HEIGHT (mm)	WIDTH (mm)	DEPTH (mm)	FIREPLACE WEIGHT (kg)	FLUE WEIGHT (kg/linear metre)
610	1250	1250	90	16

SAFETY DISTANCE FROM COMBUSTIBLE MATERIALS

FRONT (mm)	BACK (mm)	SIDE (mm)	FLOOR (mm)
800	500	500	400

SAFETY DISTANCE FROM GLASS SURFACES (mm)

500

FINISH

Outdoor black	Rusted steel
---------------	--------------

Gyrofocus

outdoor (wood-burning)

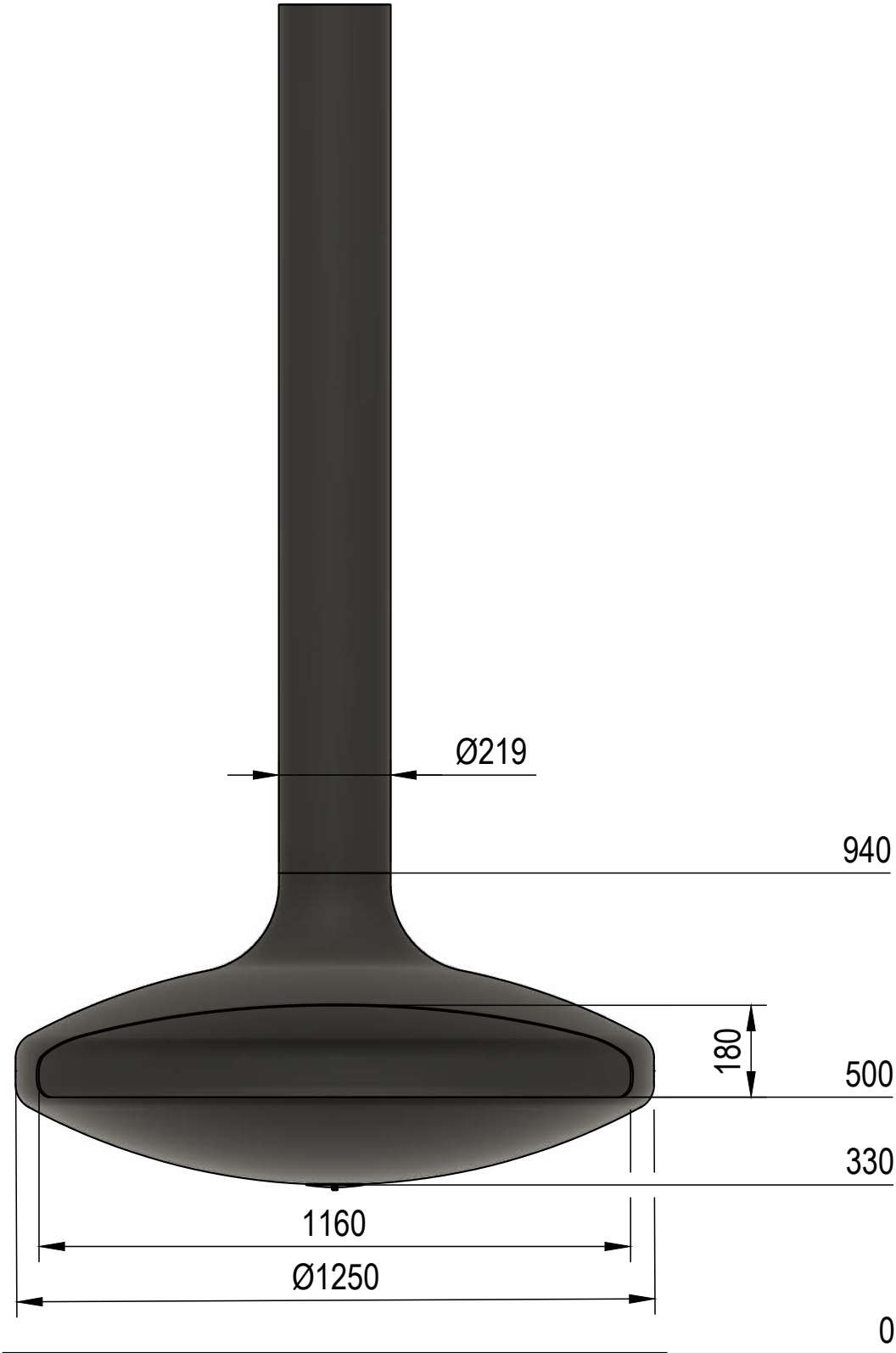



CREATE BEYOND CONVENTION

